

Manual Tapping & Drilling Machine

▶ HDT-340



▶ HDT-25



▶ HDT-32



★ Appearance Dimensions Please See Page 16/17.



Specifications		Model	HDT-340	HDT-25	HDT-32
		Stroke Method		Manual	Manual
Spindle Speed RPM (Steps)	50HZ	250-960 (9)	160-1342 (9)	55-175 (4)	
	60HZ	300-1150 (9)	190-1610 (9)	165-210 (4)	
Working Ability	1 spindle	Aluminum	M3-M16 / D3-18	M5-M24 / D5-30	M15-M38 / D16-38
		Steel	M3-M13 / D3-16	M5-M20 / D5-25	M15-M32 / D15-32
		Stainless Steel	M3-M10 / D3-14	M5-M16 / D5-20	M15-M25 / D15-D25
	2 spindle	Aluminum	T:M13 / D15	M18 / D24	M30 / D30
		Steel	M10 / D13	M16 / D20	M25 / D25
		Stainless Steel	M8 / D11	M12 / D16	M20 / D20
	4 spindle	Aluminum	M6 / D7	M10 / D12	M15 / D15
		Steel	M5 / D6	M8 / D10	M14 / D14
		Stainless Steel	M4 / D5	M6 / D8	M10 / D10
Stroke (mm)		100	140	140	
Spindle Type		MT2	MT3	MT3	
Motor		1HP-4P	2HP-6P	2HP-6P	
Weight (kg)		101	204	221	
<p>* The presenting working abilities are very related with sharpness on drill bit, good lubrication and suitable cooling. *</p>					

<http://goo.gl/ou1hnC>

Automatic Tapping Machine

▶ HD-AT12



▶ HD-AT19



★ Appearance Dimensions Please See Page 19/20/21.



Operating Video

<http://goo.gl/91RMHX>

- ▶ HT1-203
- ▶ HT2-223
- ▶ HT3-231



Specifications		Model		HD-AT12	HD-AT19	HT1-203	HT2-223	HT3-231
		Stroke Method		Automatic	Automatic	Automatic	Automatic	Automatic
Spindle Speed RPM (Steps)		50HZ	256-1278 (8)	166-829 (6)	420-1340 (3)	155-515 (3)	50-200 (3)	
		60HZ	308-1534 (8)	200-995 (6)	500-1600 (3)	190-620 (3)	60-240 (3)	
Working Ability	1 spindle	Aluminum	M3-M16	M5-M24	M2-M10	M5-M20	M10-M35	
		Steel	M3-M13	M5-M20	M2-M8	M5-M16	M10-M32	
		Stainless Steel	M3-M10	M5-M16	M2-M6	M5-M12	M10-M25	
	2 spindle	Aluminum	T:M13	M18	M8	M16	M28	
		Steel	M10	M16	M6	M12	M25	
		Stainless Steel	M8	M12	M5	M8	M20	
	4 spindle	Aluminum	M6	M10	M4	M8	M14	
		Steel	M5	M8	M3	M6	M12	
		Stainless Steel	M4	M6	M2	M5	M10	
Stroke (mm)		93	133	45	65	65		
Spindle Type		MT2	MT3	JT6	JT6	JT6		
Motor		1HP-4P	2HP-6P	1/2HP-4P	1HP-6P	2HP-6P		
Weight (kg)		112	234	97	200	250		
<p>* The presenting working abilities are very related with sharpness on drill bit, good lubrication and suitable cooling. *</p>								

Appearance Dimensions

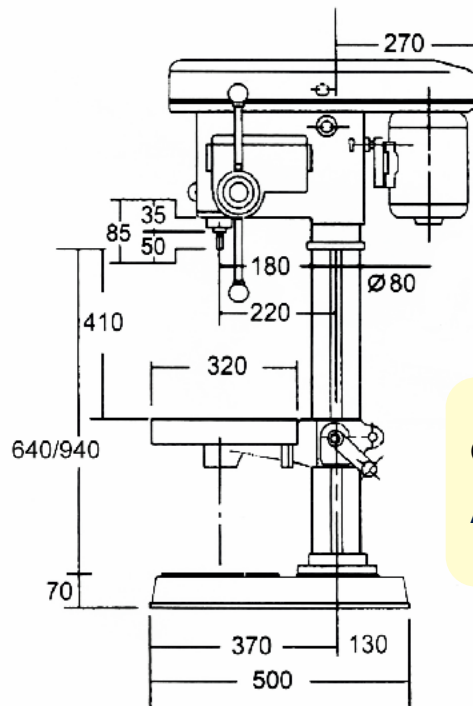
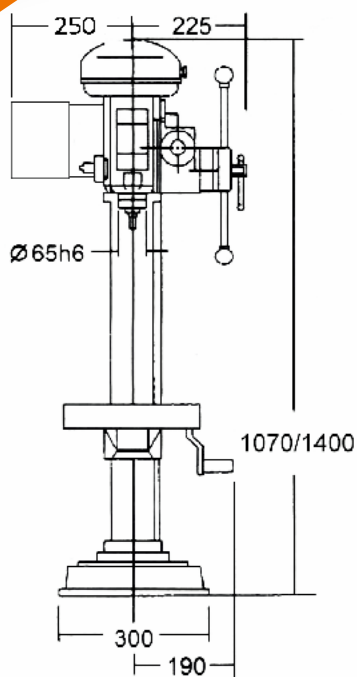

● HD-14I
Appearance Dimensions

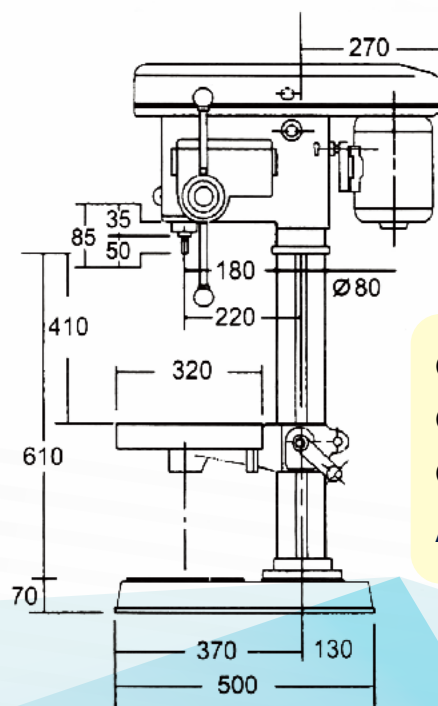
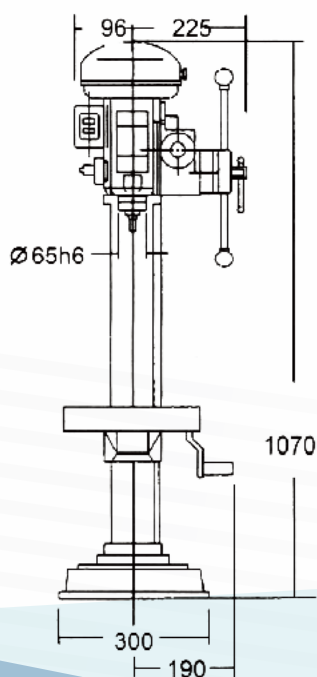

● HD-120
● HD-14
● HDT-340
Appearance Dimensions

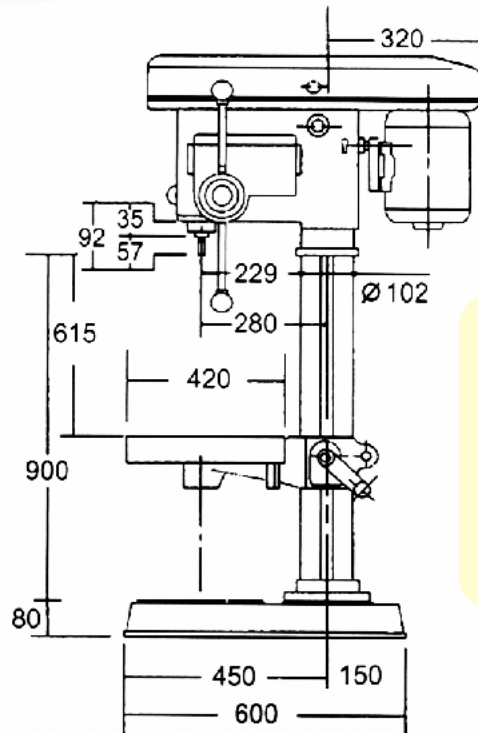
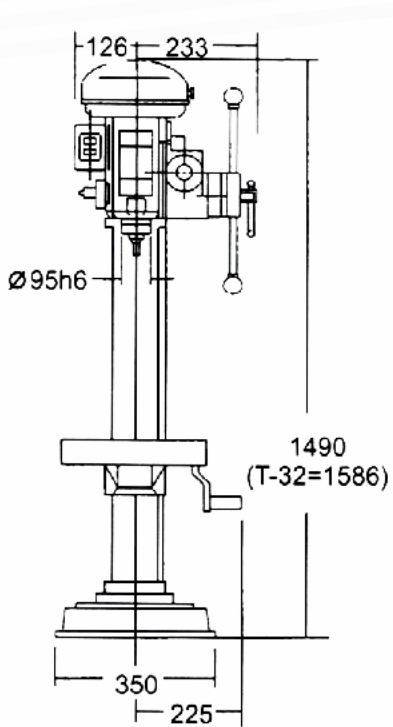

- HD-250
 - HD-25
 - HDT-25
 - HDT-32
- Appearance Dimensions

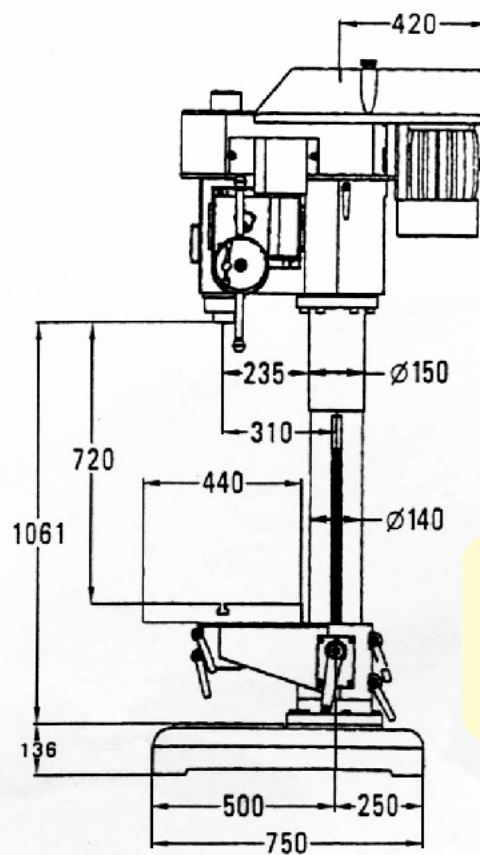
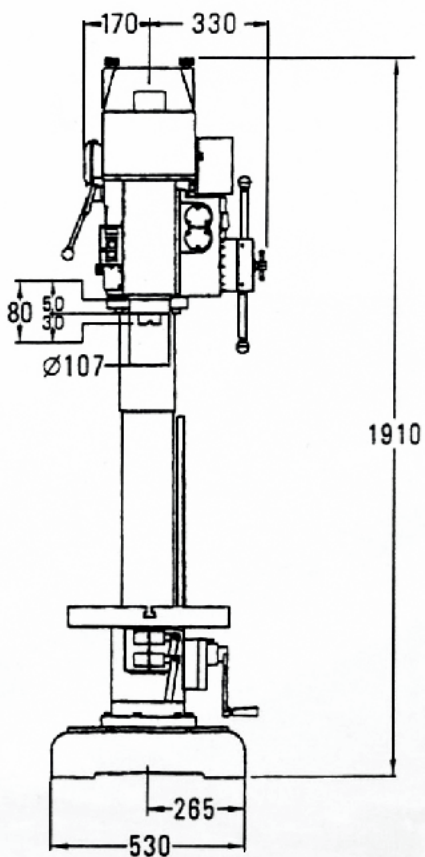

- HD-350
- Appearance Dimensions

Appearance Dimensions

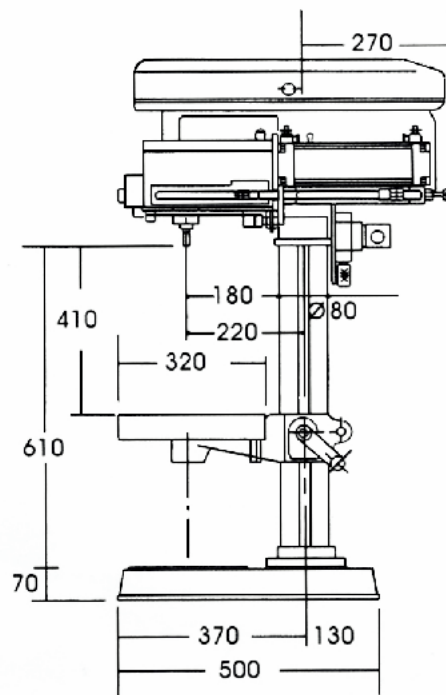
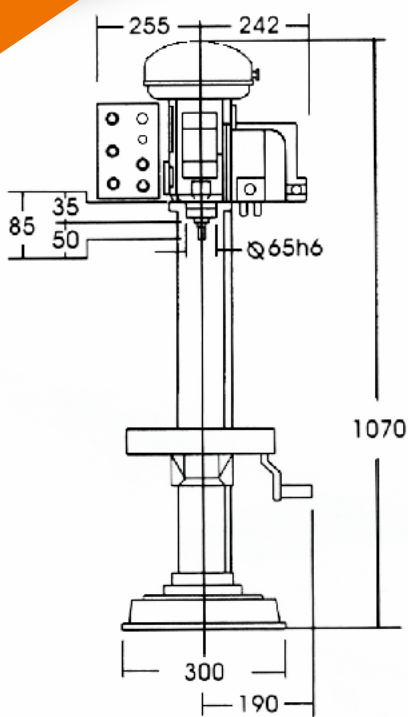

● HD-PAM520
Appearance Dimensions

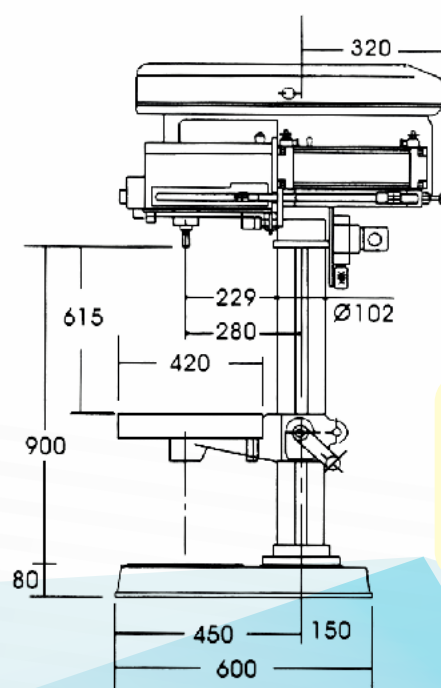
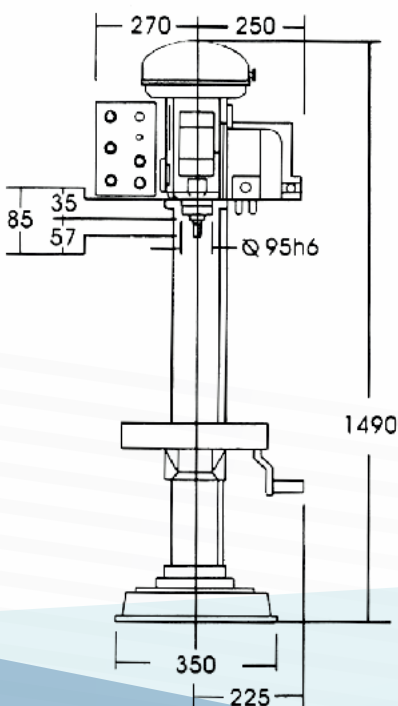

● HD-PAM520L
● HD-POM750
Appearance Dimensions

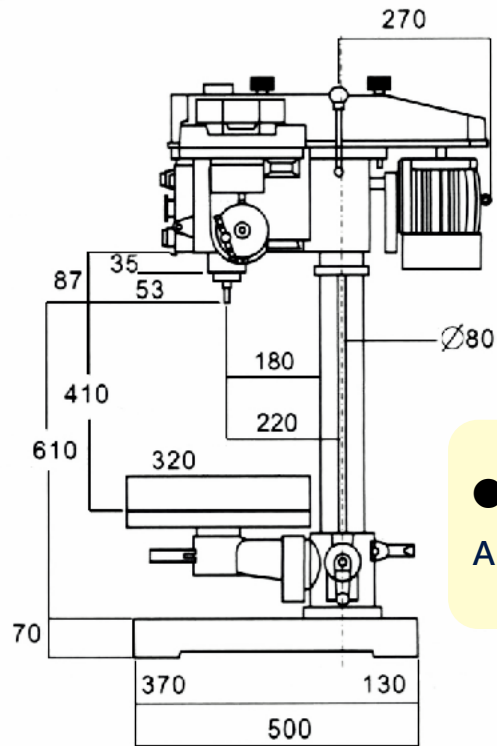
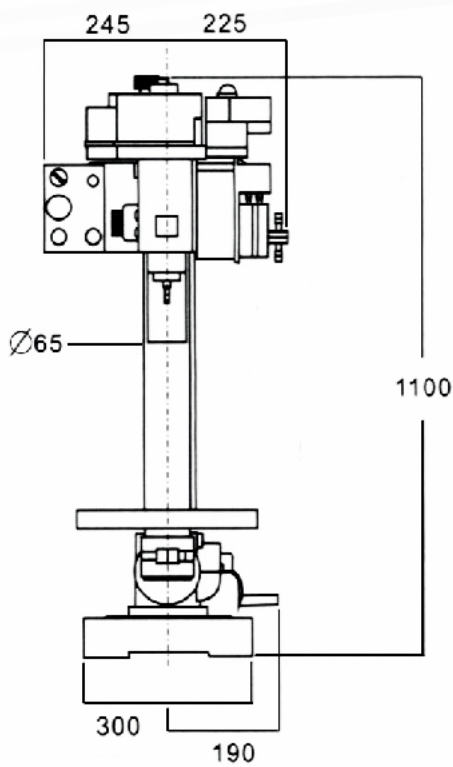

● HD-AT12
Appearance Dimensions

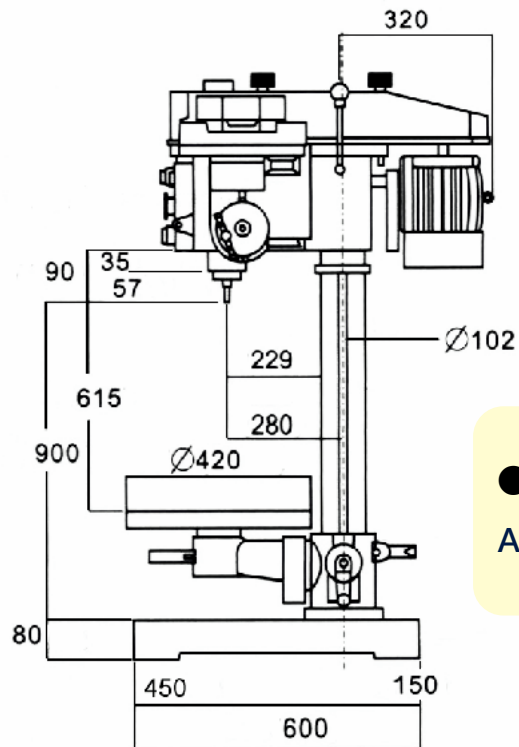
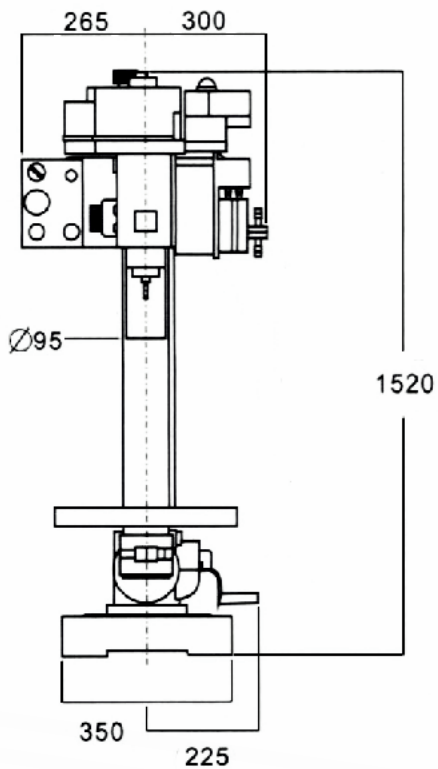

● HD-AT19
Appearance Dimensions

Appearance Dimensions

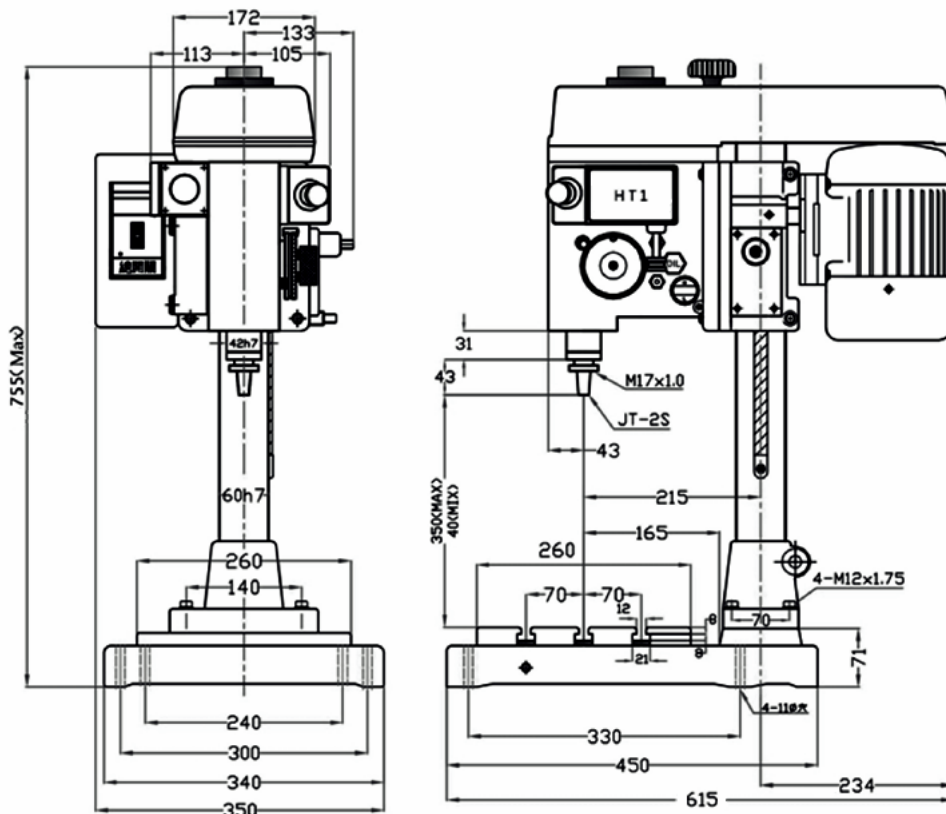

● HT1-203
Appearance Dimensions

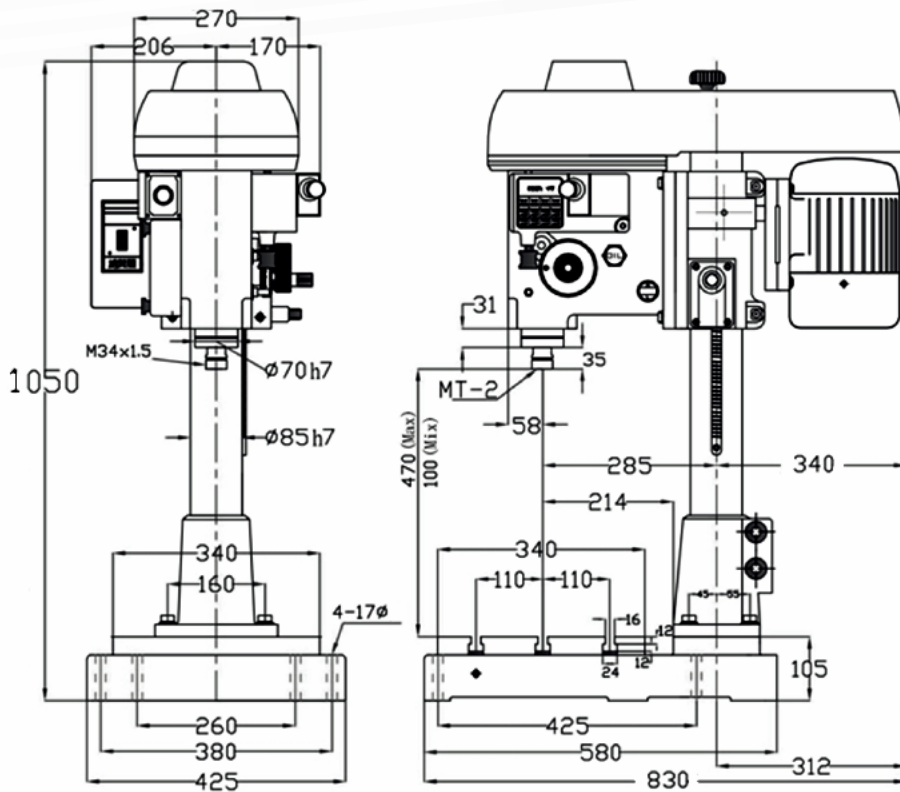

● HT2-223
Appearance Dimensions

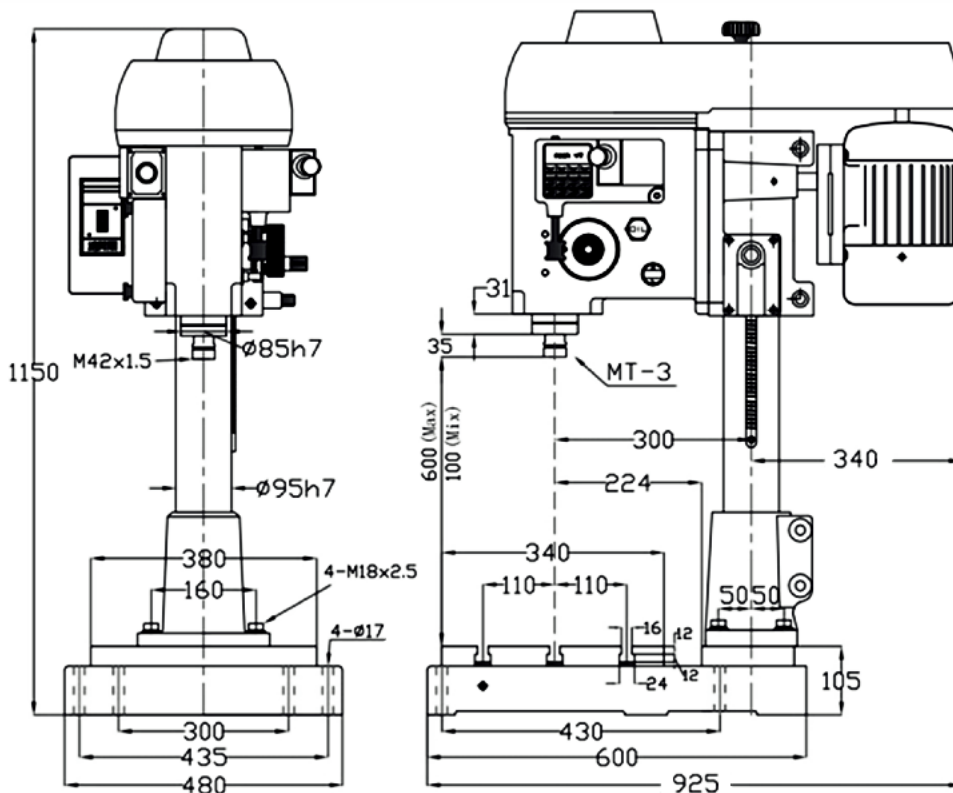

● HT3-231
Appearance Dimensions

F.N. บริษัท เอฟ เอ็น เอ็นจิเนียริ่ง จำกัด
F.N.ENGINEERING CO.,LTD.

Tel: 0-2918-4441-2,0-2918-3378 [Auto] Hotline 08-1174-3345

Fax: 0-2918-3070,0-2918-2722

Email : sale@fnengineering.com , fnengineer@gmail.com

<http://www.fnengineering.co.th>