

CEN22 Horizontal, CEN23 Vertical Type Oil-Mist Electric Lubricators

Timer



CHEN YING



CEN22-03 Standard



CEN23-03 Standard

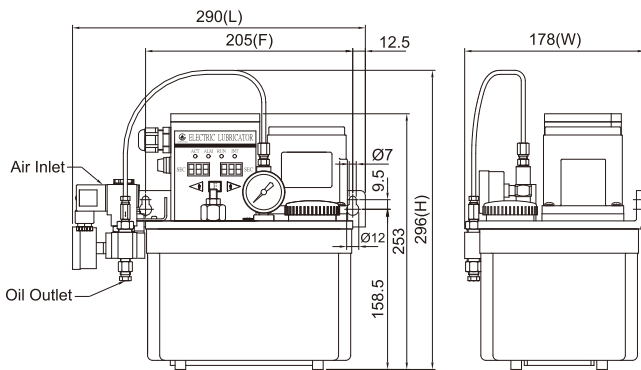

CEN22-03 Standard Externals

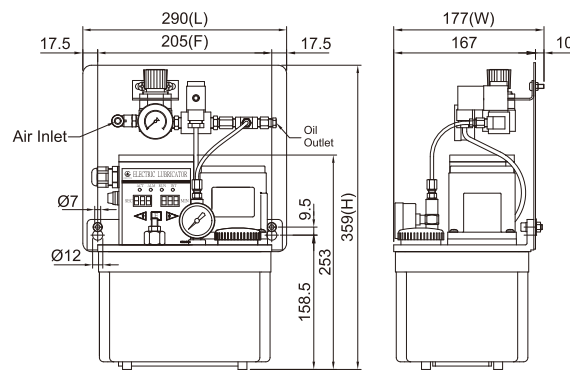

CEN23-03 Standard Externals

◆ Features

1. The timer controls the operation and interval time. The electronic box has operation and interval indicators.
2. The electronic box can automatically save the original operation and interval time while the power is suddenly off. After turning on the power, it would return to the original setting time and start the cycle again.
3. It has a feed-oil button (**F** button), press the button and the oil will feed immediately.
4. The discharge volume is stable and can be adjusted by the pressure-regulating valve. Turning the valve clockwise, the oil volume will increase, and turning anticlockwise, the oil volume will reduce.
5. When the power of the lubricator is off, the air pressure and output power will be turned off at the same time for safety.
6. It has a pressure-regulating valve, which can adjust the pressure and easy to check from the pressure gauge.
7. It has a float switch that can detect the oil volume. It will have an automatic signal when the oil level is lower than the minimum.
8. The function of CEN22, CEN23 types are similar to CEN24 (Horizontal), CEN25 (Vertical) types. The difference is CEN24, CEN25 types are without timer, and CEN22, CEN23 types are with timers.

◆ Application of Machines Equipment

The oil-mist type lubricator has cooling, lubricative and filtering effect that can reduce wear of the lubricating parts. It is suitable for cutting machines and bearings lubrication.

Model	Act Time	Interval Time	Motor	Max Volume	Max Pressure	1Ø Voltage	Ampere	Hertz	Discharge Bore	Oil Viscosity
CEN22 Horizontal CEN23 Vertical	1-999sec	1-999sec 1-999min	25W	200 cc/min	15kgf/cm ²	110V 220V	0.6A 0.3A	50/60Hz	Ø4orØ6	32-68cSt@40°C

Model	Tank Code	Tank Material	Capacity Liters	Fixed Hole Distance(mm)	Length (mm)	Width (mm)	Height (mm)	Weight (kg)
CEN22	03	Resin	3L	205	290	178	296	5.70
	04	Resin	4L	250	349	178	315	6.30
Model	Tank Code	Tank Material	Capacity Liters	Fixed Hole Distance(mm)	Length (mm)	Width (mm)	Height (mm)	Weight (kg)
CEN23	03	Resin	3L	205	240	177	359	6.40
	04	Resin	4L	250	277	185	383	7.00

CEN22 · CEN23 Single Phase Wiring Diagram

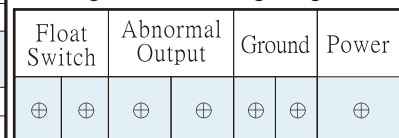

◆ Order Code :

CEN 22 **03** **1** **C** **25** **3** **※**
 Model : Oil-Mist Tank Capacity(Material) Time (Act x Interval) Voltage Motor Discharge Bore Special Request
 22 : Horizontal Type 03 : 3L (Resin) 1 : sec x sec A : 110V 25 : 25W 2 : Ø4 (With Pressure Gauge)
 23 : Vertical Type 04 : 4L (Resin) 2 : sec x min C : 220V 3 : Ø6 (With Pressure Gauge)

CEN22 Horizontal, CEN23 Vertical Type Oil-Mist Electric Lubricators